

CB7066EXT - CX7066EXT - GL7066EXT
GY7066DEXT - GY7066REXT
CB7067EXT - CX7067EXT - GL7067EXT
GY7067DEXT - GY7067REXT

hotbath
italian bathroomware

Trim parts for thermostatic mixer with 2 stop valves
 Parti esterne per miscelatore termostatico con 2 rubinetti d'arresto
 Parties extérieures pour mitigeur thermostatique avec 2 robinets d'arrêt
 Partes exteriores para termostático con 2 llaves de paso
 AP-Teile für Thermostatabatterie mit 2 UP-Ventilen
 Afbouwdelen voor thermostatische mengkraan met 2 stopkranen

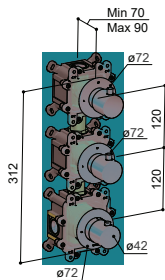

COBBER	COBBER-X	GAL	GUY DIAMOND	GUY ROW
CB7066EXT	CX7066EXT	GL7066EXT	GY7066DEXT	GY7066REXT

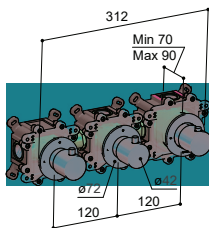

COBBER	COBBER-X	GAL	GUY DIAMOND	GUY ROW
CB7067EXT	CX7067EXT	GL7067EXT	GY7067DEXT	GY7067REXT

BEFORE STARTING / PRIMA DI INIZIARE / AVANT DE COMMENCER / ANTES DE EMPEZAR / VOR DEM START / VOORDAT JE BEGINT

 P bar	 MAX 5 1 MIN	 3	 15s	 OFF	RECOMMENDED: BALANCED PRESSURES
 T °C	 MAX 80	 60 45			

Once the mixer is installed in the wall, cut along the finished wall and remove the plastic protection

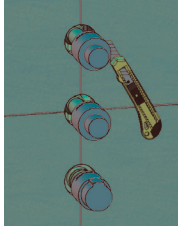

Put silicone between the cover plate and the wall

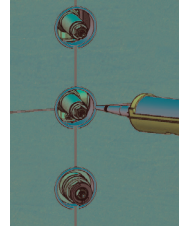

TRIM FIXING

1. Fix the cover plate (1) on the threaded rod (2).
2. Screw the adapter (4) with their O-ring (3), until the plate (1) is against the wall.
3. Fix the insert (5) and fix the screw (6).
4. Position the handle (7) on the insert (5) and rotate until the vertical position is reached.
5. Screw the grub screw (8) with a 2,5 mm Allen key.
6. Screw the lever (9).
7. Fix the cover plate (10) on the chromed ring (11).
8. Fix the handle (12) and screw the grub screw (13) with a 2,5 mm Allen key.
9. Fix the cap (14).

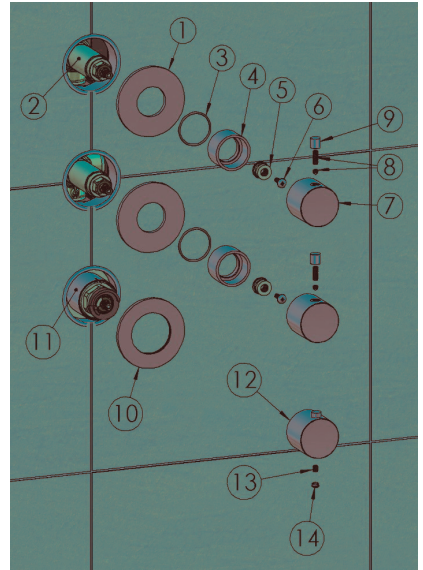

INSTALLATION

REPLACEMENT OF THE STOP VALVE HEADWORKS

1. Close the water inlets.
2. Remove the lever (1) and the grub screw (2) with a 2,5 mm Allen key.
3. Remove the handle body (3)
4. Unscrew the chromed adapter (4), being careful not to lose the O-ring (5).
5. Remove the cover plate (6).
6. Unscrew the threaded rod (7).
7. Unscrew the headwork (8) anti-clockwise, with a 17 wrench.
8. Before replacing the headwork, clean thoroughly and grease the inner seat of the body.
9. Replace the headwork (8) and screw the threaded rod (7).
10. Assemble the trim following the instructions of TRIM FIXING.

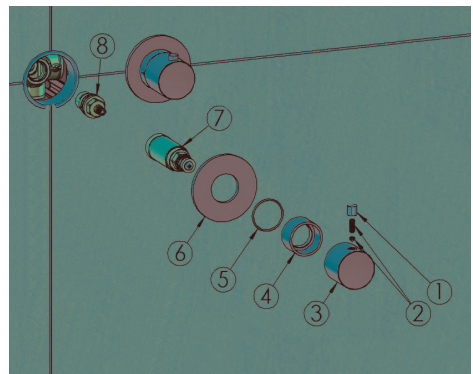

MAINTENANCE

REMOVE AND CLEAN THERMOSTATIC CARTRIDGE

1. Remove the cup (1), Unscrew the grub screw (2) with an 2,5 mm Allen key
2. Remove the handle (3). Remove the plate (4).
3. Close the water inlets, in order to isolate the thermostatic cartridge.
4. Remove the stop ring (5).
5. Unscrew the thermostatic cartridge (6) anti-clockwise with a 30mm wrench.
6. Remove the thermostatic cartridge (6) and clean its filters under running water or leave to soak in vinegar in presence of limestone. Grease the O-rings and, if damaged, replace them with new ones. 2x OR 2175 mm 44,17 x 1,78 1x OR 2187 mm 47,35 x 1,78

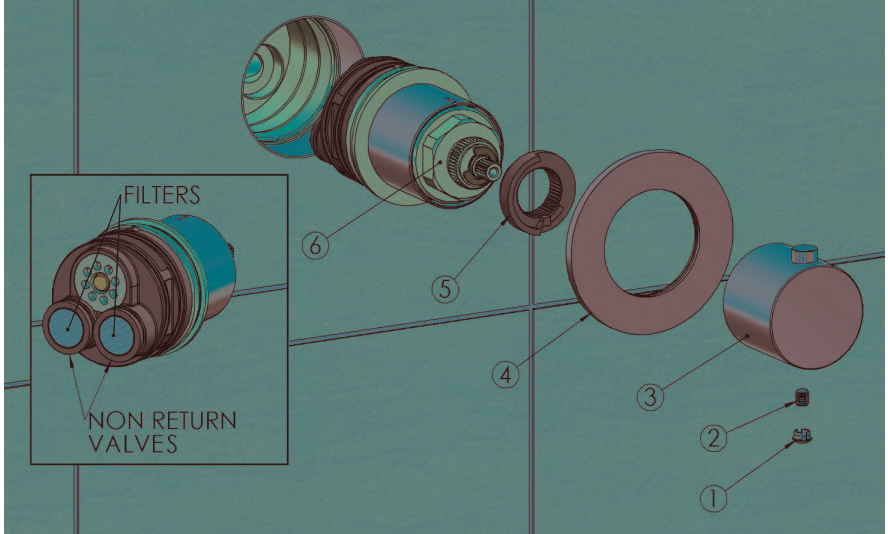

RE-INSTALL THE THERMOSTATIC CARTRIDGE

1. Check that the reference on the body cartridge is upward
2. Match the reference on the body of the thermostatic cartridge with the reference in the mixer body
3. Screw the thermostatic cartridge (6) clockwise with a 30mm wrench

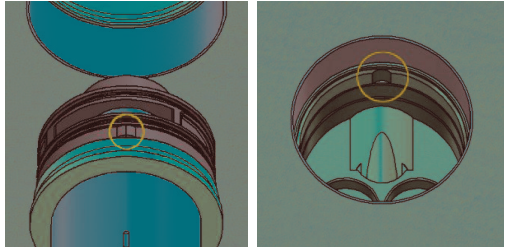

POSITION OF THE STOP RING

1. Place the stop ring (5) as shown in the image below.
2. Using the handle, rotate the broached rod (A) to reach the set temperature of 38°C (check the temperature with a thermometer).

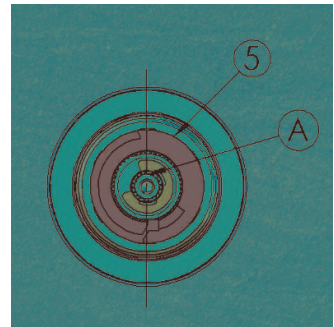

CLEANING - PULIZIA - NETTOYAGE - REINIGUNG - LIMPIEZA - REINIGING

		WARNING	✓		✗		
CR CHROME	GN BRUSHED NICKEL	Inoxidable electrolytic finish Finitura elettrolitica inossidabile Finition électrolytique inoxydable Inoxidierbare elektrolytische Ausführung Acabado electrolytico inoxidable Inoxidable elektrolitische afwerking					
		Natural metal finish: patina will form over time Finitura di metallo naturale: si formerà una patina nel tempo Finition en métal naturel: une patine se formera avec le temps Natürliche Metallausführung: eine Patina wird sich mit der Zeit bilden Acabado metálico natural: la pátina se formará con el tiempo Natuurlijke metalen afwerking: na verloop van tijd vormt zich patina					
	BB BRUSHED BRASS	Aged metal finish: patina will form over time Finitura di metallo invecchiato: si formerà una patina nel tempo Finition en métal vieilli: une patine se formera avec le temps Gealterte Metallausführung: eine Patina wird sich mit der Zeit bilden Acabado de metal envejecido: la pátina se formará con el tiempo Verouderde metalen afwerking: na verloop van tijd vormt zich patina					
	AB AGED BRASS						
TB TUSCAN BRONZE	WH MATT WHITE	Varnished finish: subject to scratches if not properly handled Finitura verniciata: soggetta a deterioramento se non trattata correttamente Finition vernie: sujette aux rayures si ne pas traitée correctement Lackierte Ausführung: Kratzer bei unsachgemäßer Behandlung Acabado barnizado: puede rayarse si no se manipula correctamente Gelakte afwerking: gevoelig voor krassen als er niet goed mee wordt omgegaan					
	AI AGED IRON	Plated finish: subject to scratches if not properly handled Finitura placcata: soggetta a deterioramento se non trattata correttamente Finition plaquée: sujette aux rayures si ne pas traitée correctement Plattierte Ausführung: Kratzer bei unsachgemäßer Behandlung Acabado chapado: puede rayarse si no se manipula correctamente Geplaatde afwerking: gevoelig voor krassen als er niet goed mee wordt omgegaan					
BBP BRUSHED BRASS PVD	BCP BRUSHED COPPER PVD	Inoxidable PVD finish Finitura PVD inossidabile Finition PVD inoxydable Inoxidierbare PVD Ausführung Acabado PVD inoxidable Inoxidable PVD afwerking					
PBP POLISHED BLACK PVD	MBP MATT BLACK PVD						

TERMS OF SALE AND WARRANTY
CONDIZIONI DI VENDITA E GARANZIA
CONDITIONS DE VENTE ET GARANTIE

CONDICIONES DE VENTA Y GARANTÍA
VERKAUFSBEDINGUNGEN UND GARANTIE
VERKOOP- EN GARANTIEVOORWAARDEN

**NETHERLANDS
BELGIUM
LUXEMBOURG
UK AND IRELAND**

**ALL COUNTRIES
(EXCEPTED BENELUX, UK AND IRELAND)**

<https://www.hotbath.nl/garantie>

<https://hotbath.it/en/termsforsale>



Hotbath B.V.
Nieuwland Parc 210
2952 DC Alblisserdam
Nederland
E info@hotbath.nl
W hotbath.nl



Hotbath Srl
Via Marco Polo 135/D
I-55049 Viareggio
Italy
E info@hotbath.it
W hotbath.it

hotbath
italian bathroomware